

Aciéries Hachette & Driout

Une des plus grandes fonderies européennes



INTRODUCTION

Ongoing industrial investments and continuous training

In order to respond efficiently to the specific demands of customers, the site at Saint-Dizier follows an ongoing investment-programm in Industrial facilities and continuous training of its employées in quality.

« Hi-Tech » steels

The A.O.D. process, allows a top quality refining and gives to Aciéries Hachette et Driout a real scientific advantage, necessary to respond to the growing specific demands from customers. With the A.O.D. process in particular, AHD is developing the production of very special alloyed steels to supply the Offshore, Petrochemistry, Chemical, Shipbuilding, Industries.

140
years

1869-2009

A diversified production to respond to specific markets

Aciéries Hachette et Driout operates from design to finish-machined steel castings. The know-how from AHD is used in Industries such as : Public Works machines, Valves and Pump Industries, Army and Defense, Hydraulic, Railway, Shipbuilding, Handling Industries, castings for Architecture, ... The « Arche de la Défense », the T.G.V. Railway station at Paris Charles de Gaulle Airport, the Paris Charléty stadium, the British Parliament, ... have all required the knowledge of AHD which is able to meet the global demands of such markets. Today, AHD exports worldwide, including USA, Japan, South Africa, Australia, ...



Aciéries Hachette et Driout – www.ahd.fr

11, avenue du Général Sarrail – 52100 SAINT-DIZIER / FRANCE

Aciéries Hachette & Driout

Une des plus grandes fonderies européennes



INTRODUCTION - next

Our strength

- Capacity from 20 kg to 8 tons (unit weight)
- Pattern shop on site
- Hand and Machine moulding
- ARC furnaces and A.O.D. refining
- All kinds of steel : carbon, low alloy, stainless steel and austeno-ferritics, nickel based, ...
- Spectrometers, laboratories, CND
- On site, machining shop
- Qualifications : ISO 9002 – Lloyds – TÜV – Korean Register – Norsok – Agreement Caterpillar, Siemens, ...
- Production of 13 000 T per year, 50 % Export

**140
years**

1869-2009



Aciéries Hachette et Driout – www.ahd.fr

11, avenue du Général Sarrail – 52100 SAINT-DIZIER / FRANCE



DUPLEX STEELS

Duplex Steels

Duplex steels owe their name to the austenitic-ferritic structure that characterizes them and gives them their high mechanical properties.

Although not of recent appearance (their technical maturity dates of ten years), they remain, an innovative material in many industries.

Their development has actually begun with the exploitation of oil in the North Sea, where difficult conditions of service valued all their properties.

Between stainless steels and the nickel based, Duplex steels are characterized by levels of Chromium of 20-25%, Nickel from 4 to 9%. Without all their abilities known today, a consensus exists among users after testing, to recognize their high level of performance in :

- Resistance to corrosion in atmospheres loaded with chlorides, fluorides or ambiances containing sulfuric acid, phosphoric, ...
- Resistance to abrasion, which increases its interest for moving machinery
- Mechanical strength that makes them particularly wanted for high pressure equipments.

Main areas of use

- Oil and gas industries, including offshore and onshore
- Chemicals and petrochemicals
- Industries of cleaning of pollution: gas desulphurization, industrial water treatment
- Shipbuilding and transport of chemical products
- Pulp and paper industry
- Hydropower
- All applications of desalination of seawater
- and more generally all applications that require a combination of good resistance to corrosion and high mechanical properties.

140
years

1869-2009



Aciéries Hachette & Driout

Une des plus grandes fonderies européennes



HEAT TREATMENTS

A large installation of heat treatments including furnaces specially designed to perform quenching of Austenitic and Austenitic-ferritic steels or ANY OTHER TREATMENT OF CARBON STEEL or HIGH ALLOYED STEEL.

- Furnaces for loads up to 30 tons
- Adapted quenching tanks
- Very short transfer time
- Our elaboration facilities (Arc furnaces and AOD) and heat treatment ovens allow us to realize castings in nearly all grades of steel existing on the market.

140
years

1869-2009

Furnace type « Bell » with « moving hearth »

Equipped exclusively with high-speed burners, the oven "bell type" features a perfect seal. It allows processing of high performance homogenization and especially designed for special, Nickel based and self-hardening.

MGR robotized ovens

2,5 m x 1,5 m x 1,2 m –max. temperature : 1240°C

The main advantages of these ovens are their uniformity of temperature and the very short transfer time between the furnace and the quenching tank, thanks to the fully automatic control system by computer which simultaneously adjusts the cooling system.



Aciéries Hachette et Driout – www.ahd.fr

11, avenue du Général Sarrail – 52100 SAINT-DIZIER / FRANCE

Aciéries Hachette & Driout

Une des plus grandes fonderies européennes



METHODES

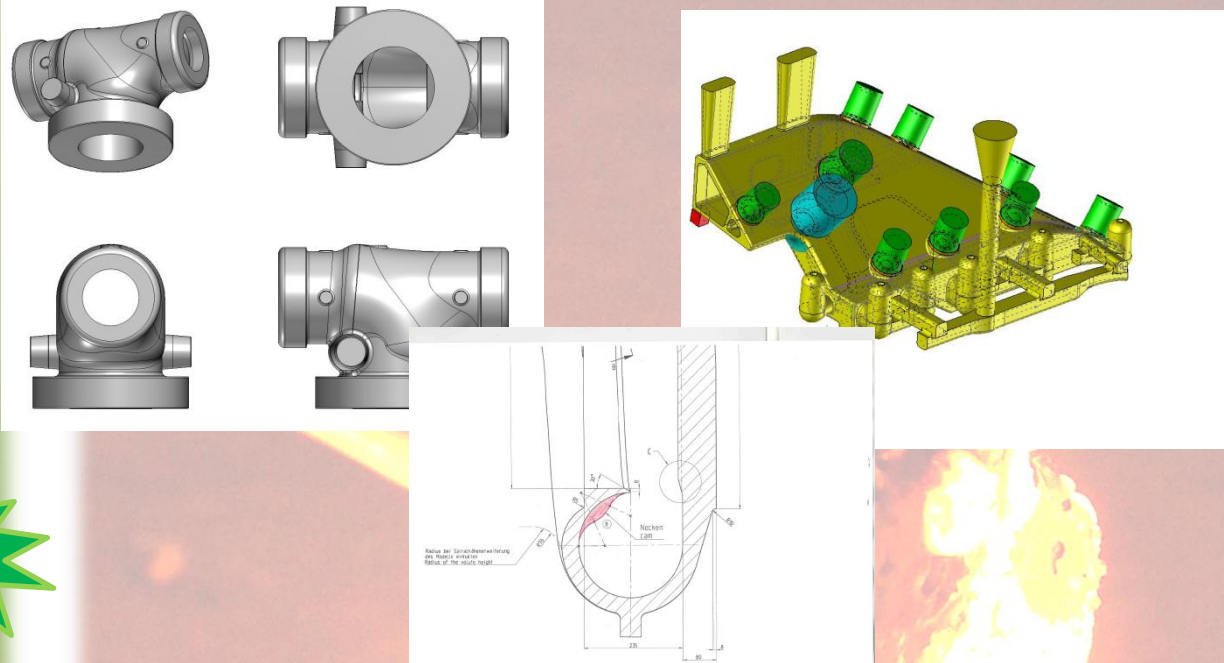

140
ans

1869-2009

Our modern methods of conception.

The need to continually optimize the manufacture of parts to satisfy our customers, made we invest in the latest technical facilities. Among them, softwares Novaflow and Novasolid.

Control of complex processes.

By using electronic media (Internet, ...) we use software that allow us to receive and develop 3-D drawing of castings. The softwares Novaflow and Novasolid allow us to analyze the filling and cooling of the casting and thus to determine the best way to optimize the pouring and risers system.

From the concept of a casting in 3-D, we can make tooling and machine parts on our CNC machines.

Aciéries Hachette et Driout – www.ahd.fr

11, avenue du Général Sarrail – 52100 SAINT-DIZIER / FRANCE

Aciéries Hachette & Driout

Une des plus grandes fonderies européennes



MACHINING

Our machine shop is located on the same site as the foundry. Hachette & Driout is equipped with the most modern facilities for complete machining of single castings or series on machining centers, lathes and vertical parallel, boring, milling, all digitally controlled.

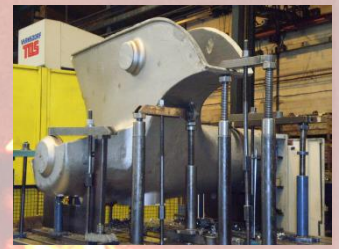

Horizontal Machining Center:

- 3 Hyundai - 2 paletts (X=1000 Y=800 Z=850)
- Mori-Seiki NH 6300 DCG 2 paletts (X=900 Y=800 Z=950)
- TREVISAN DS 600-200 1 Palet 900x900 Passage 1600 (X=1400 Y=1000 Z=1100)

Vertical Machining Center :

- 1 x TOS HULIN (X=2395 Y=1500)

Boring machines :

- 1 x GRAFF (x=3500 Y=2000 Z = 1000)
- 2 TOS VARNSDORF (1600x1120x900 pin $\varnothing = 100$)

Milling machines :

- 1 Anayak (X3200 Y 1200 – Z 1500)

Horizontal machining Center :

- 1 Mazak 50 N CNC max. $\varnothing 805$ – Length between points 1500
- 2 Horizontal centers with hydr. Duplicator (Transv. maxi 830), length between points 1500

Vertical boring machine :

- 1 TOS SKIQ 20 CNC \varnothing tray 2340 – passage 2200– height 1750
- 1 Siemens \varnothing tray 2340 – height 1960

TO COME : Machining center TOYADA

140
ans

1869-2009